

2 TIER FACETED GLASS TABLE / FLOOR LAMP

These instructions are provided for your safety.
Please read carefully before commencing work and retain for future reference.

SAFETY INFORMATION

- * The supply cable runs through the inside of the portable lamp. Take care not to place undue stress on the cable whilst unpacking to prevent the possibility of a poor connection.
- * If the external flexible cable of the lamp is damaged it shall be exclusively replaced by the manufacturer or his service agent or a similar qualified person in order to avoid a hazard.
- * If you are in any doubt consult a person competent to give advice on the assembly of electrical equipment.
- * To prevent electrocution switch off at the mains supply before assembling or maintaining this fitting. Ensure the plug is not connected to any power supply and read instructions before assembly.
- * Always be sure to use the correct type and wattage of bulbs as indicated on the product. Do not exceed wattage stated.
- * When changing the bulb, always switch off at the mains and allow the old bulb to cool down before handling. Dispose of old bulbs carefully.

FLOOR LAMP ASSEMBLY INSTRUCTIONS

1. Unpack the floor lamp and remove all packaging. Be careful that you do not scratch surface of the stems whilst removing plastic wrapping.
2. Cover floor with a soft cloth to avoid damage to the flooring and surface of the product then lay this product out on the floor. Assembly should take place with the product lying flat.
3. Where required remove the plastic / cardboard cable protectors that are fitted at cable entry points inside stems and floor lamp base.
4. Firmly hold the lamp holder section and then screw top stem into the upper section together, taking care to hold stems parallel to avoid cross threading. ①
5. Firmly hold the lamp holder section and then screw the middle stem into the upper section together, taking care to hold stems parallel to avoid cross threading. ②
6. Hold assembled stems firmly and screw lower stem into the assembled stems. ③ Make sure that the threads do not become crossed. If in doubt unscrew stem, then start again. **Take care not to over tighten.**
7. With the product laid on a covered surface attach the base onto assembled stems. Make sure that the threads do not become crossed. ④ If in doubt unscrew base, then start again. **Take care not to over tighten.** Stand the floor lamp upright and ensure all assembled sections are fully tightened, take care not to over tighten.
8. Attach faceted glasses through small holes in lower ring whilst using clips on the glasses. ⑤
9. Attach faceted glasses through small holes in top ring whilst using clips on the glasses. ⑥
10. **Fit bulb**, type and wattage as indicated on fitting. ⑦ **The wattage indicated must not be exceeded.**
11. Your floor lamp is now ready for use.

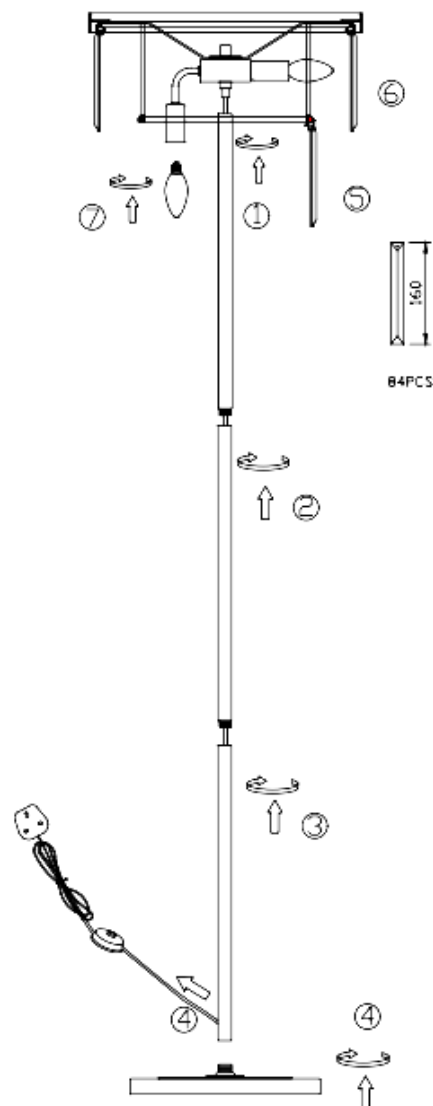
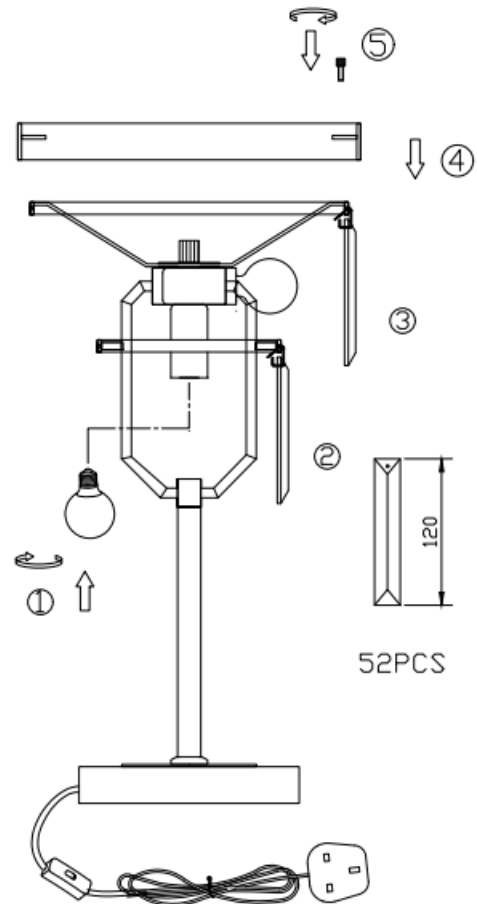

TABLE LAMP ASSEMBLY INSTRUCTIONS

1. Unpack the product and remove all packaging. Be careful that you do not scratch surface of the stems whilst removing plastic wrapping.
2. Undo finial and remove the washer then place the large ring into position then secure this into place using the washer and finial.
3. **Fit bulb**, type and wattage as indicated on fitting. ① **The wattage indicated must not be exceeded.**
4. Attach faceted glasses through small holes in lower ring whilst using clips on the glasses. ②
5. Attach faceted glasses through small holes in top ring whilst using clips on the glasses. ③
6. Fit decorative plate over the larger top ring ④ and secure into position with fixing screws. ⑤
7. Your floor lamp is now ready for use.



GENERAL INFORMATION

This floor lamp is designed for internal use only.

Do not use polish or an abrasive cleaner - just a soft dry cloth.

To register your product for an extended five-year warranty, please complete the simple form at

www.darlighting.co.uk/warranty

You'll need to fill in the details of the product, the retailer you purchased it from, and also the installer and the installation.

Please also upload a clear copy of the original purchase invoice or receipt to complete this registration.

UK: där Lighting Ltd, Wildmere Road, Banbury, Oxon, OX16 3JZ

Ireland & EU: Dar Lighting Ireland Limited, Suite 108, Q House, 76 Furze Road, Sandyford Industrial Estate, Dublin 18